

Advances in Magnet Technology

DMTC Meeting
Cleveland, OH Feb 2, 2010
Peter C. Dent

Electron Energy Corporation

Types of Commercial Magnets

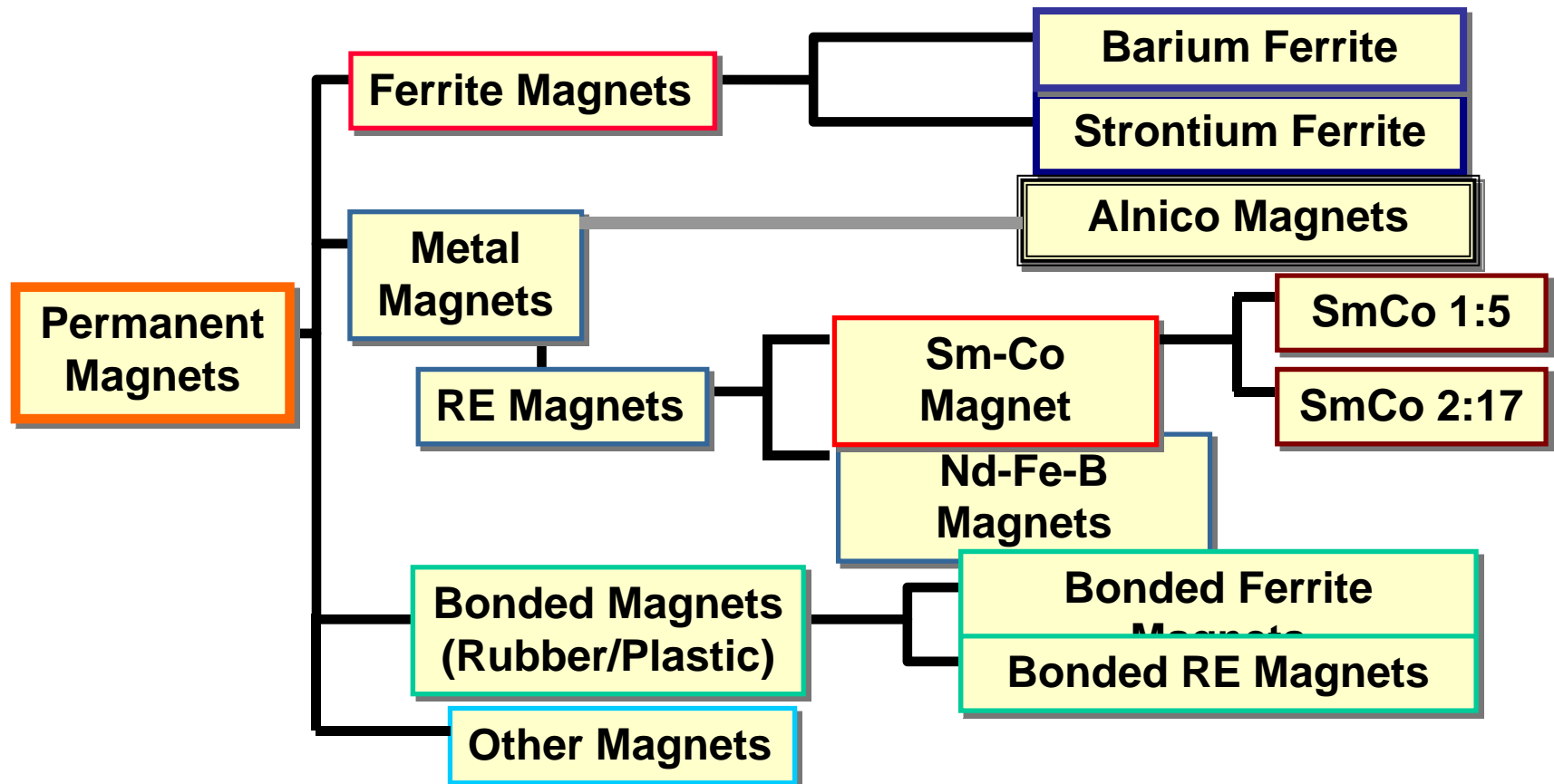

270 Years of Progress in Magnet Technology, --it's not over

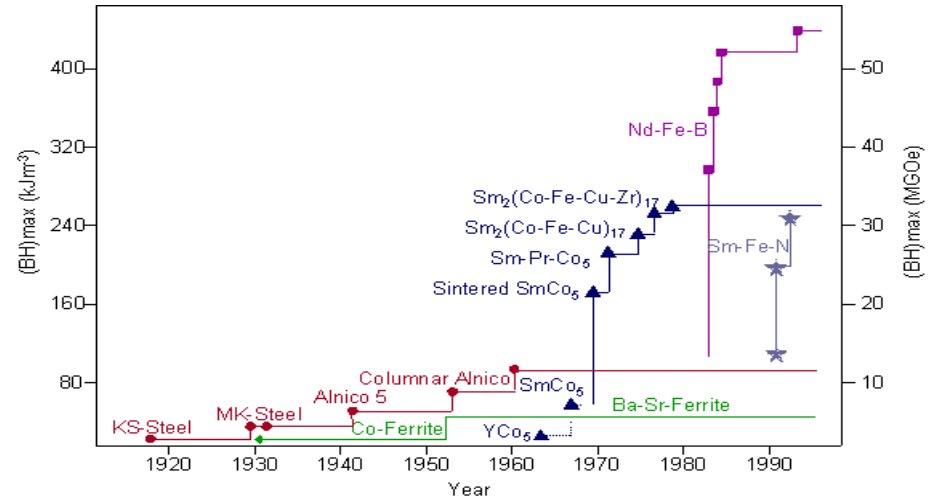

In the last 100 years, the strength of the magnets [(BH)_{max} and H_c] increased dramatically (by a factor of 100)
 Each magnet produces half a Joule of magnetic energy, yet the size has decreased by a thousand fold.
 The nanocomposite technology could yet again halve the size

Typical Manufacturing Process for Sintered Sm-Co Magnets

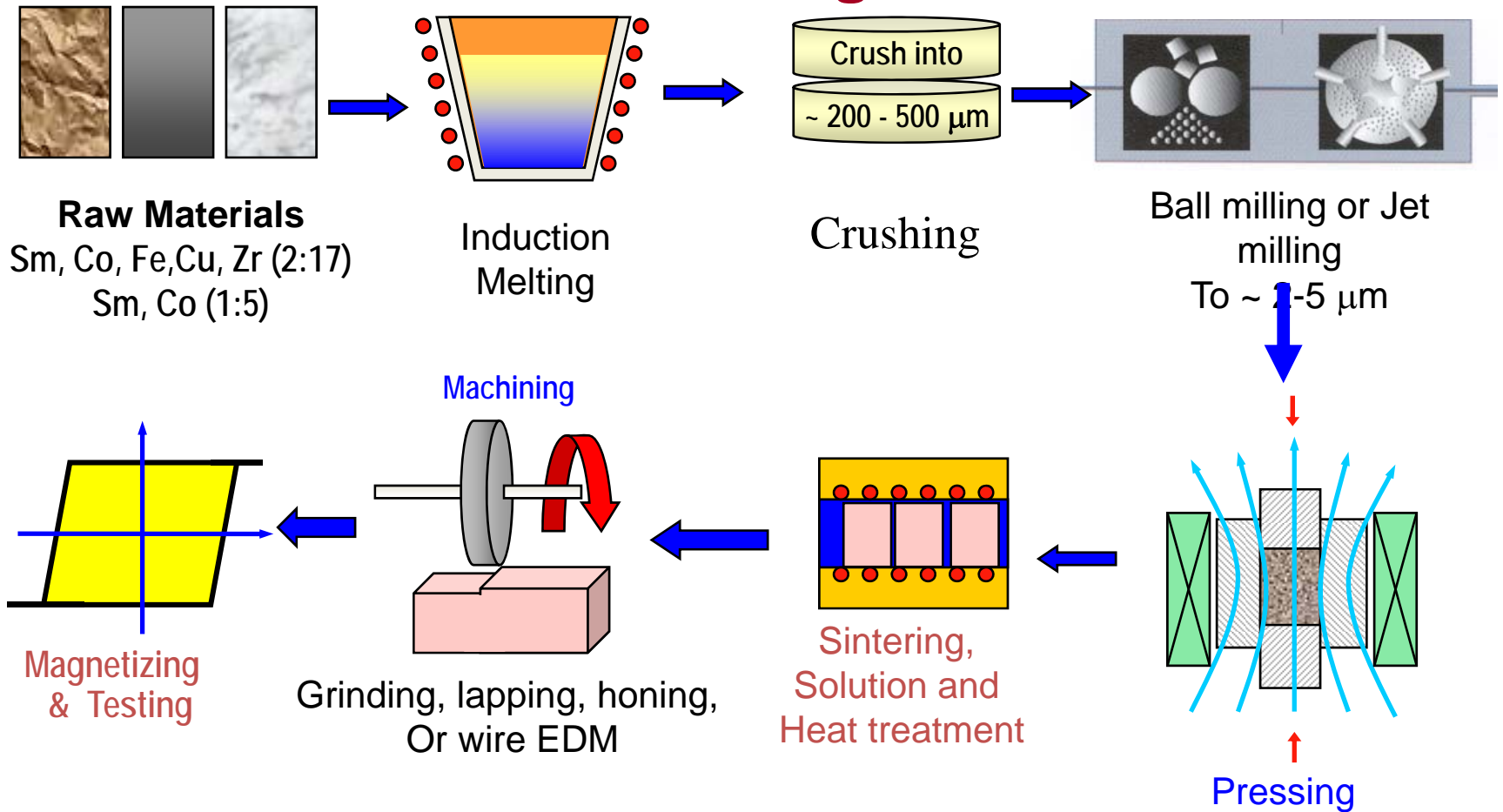

Why Nanocomposite magnets?

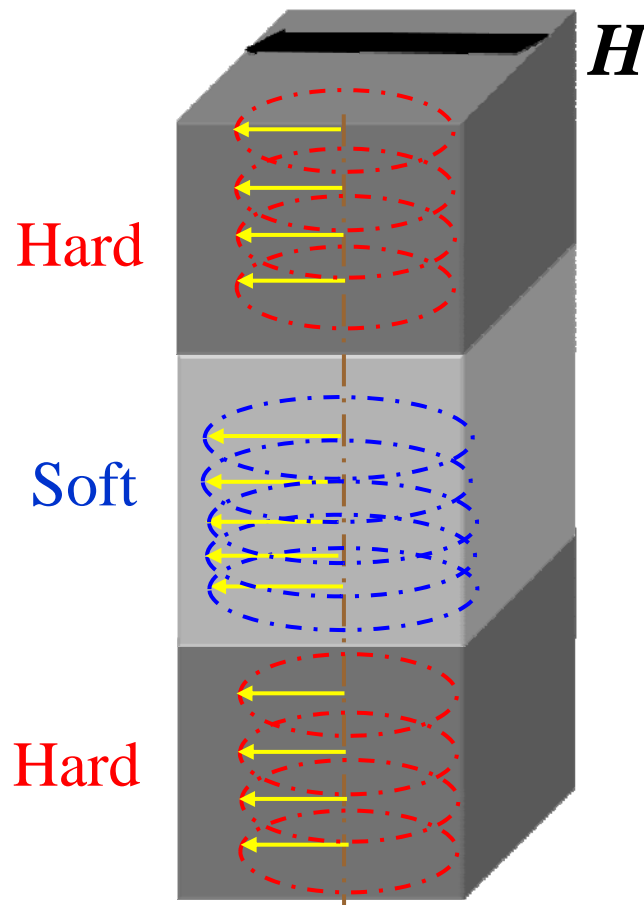

- Theoretical micromagnetic calculations: almost **double** $(BH)_{max}$
- Physical principle: **magnetic exchange hardening** of soft magnetic phases by hard magnetic phase.

- RARE EARTH MAGNETS
- MAGNET DESIGN
- MAGNET SYSTEMS

Questions?

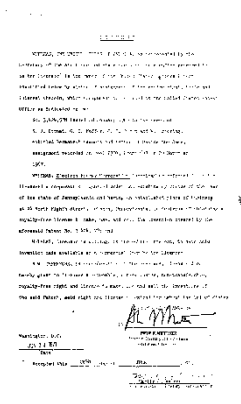

Peter C . Dent
 Electron Energy Corporation
 924 Links Ave.
 Landisville, PA 17538
 (717) 898-2294 ph
 (717) 459-1001 direct
 (610) 349-5525 cell
pcd@electronenergy.com
www.electronenergy.com

